

**SUMIDOURO**  
ESCALA: 1/25

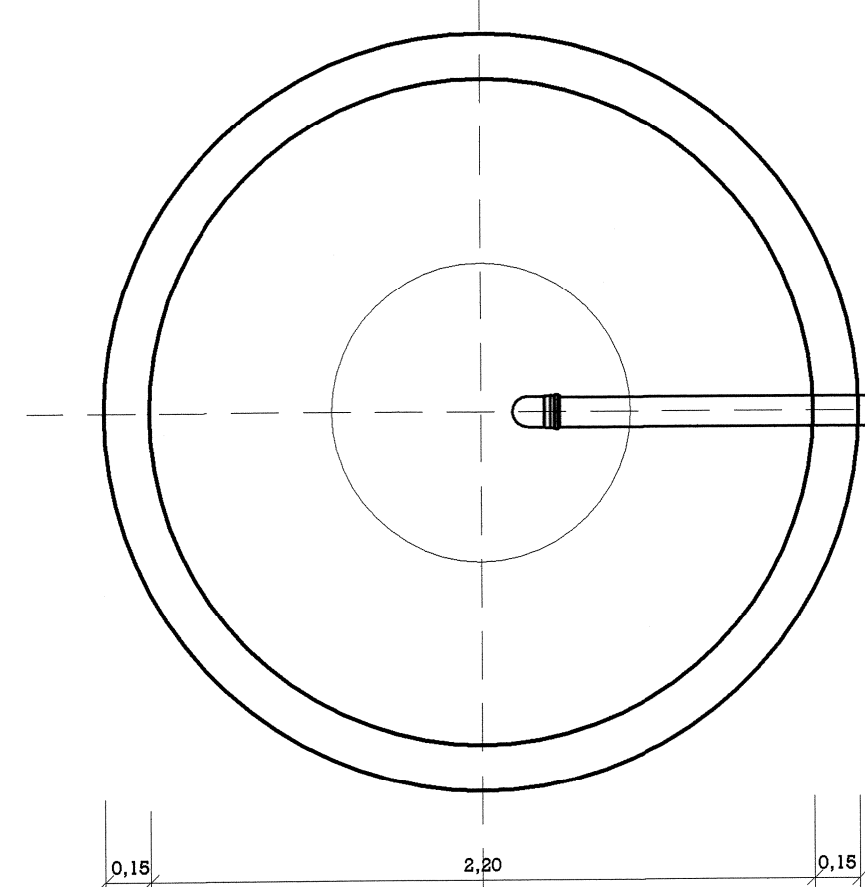

**FOSSA SÉPTICA**  
ESCALA: 1/25

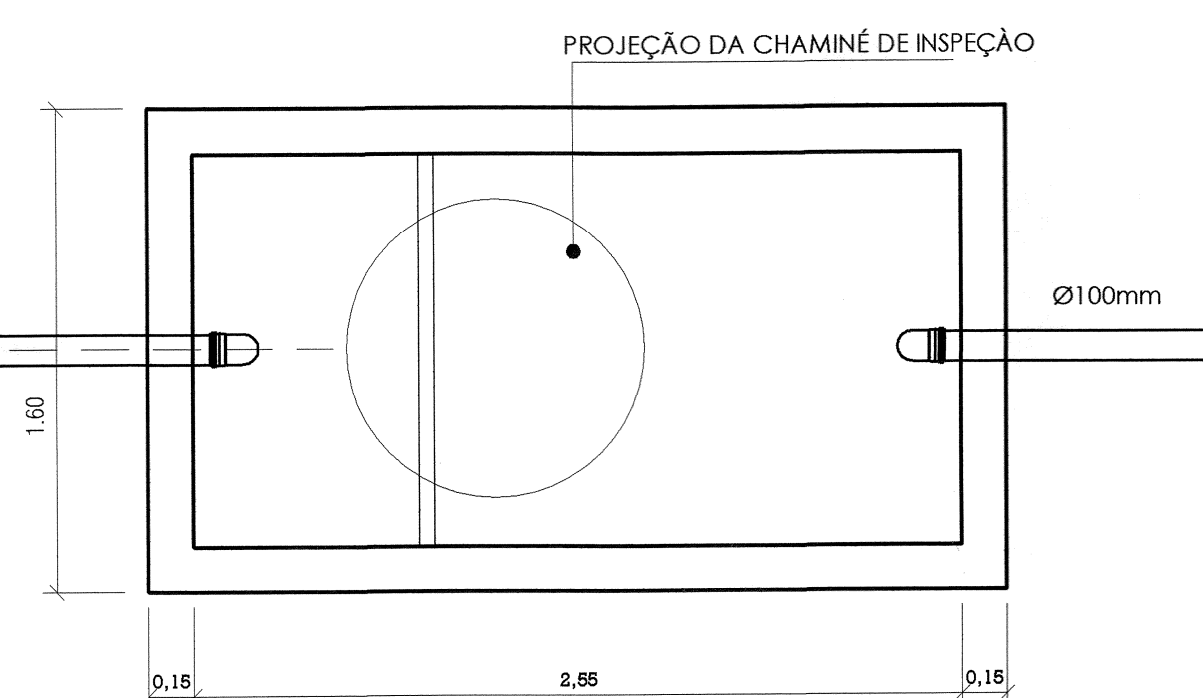

**CAIXA DE INSPEÇÃO**  
ESCALA: 1/10

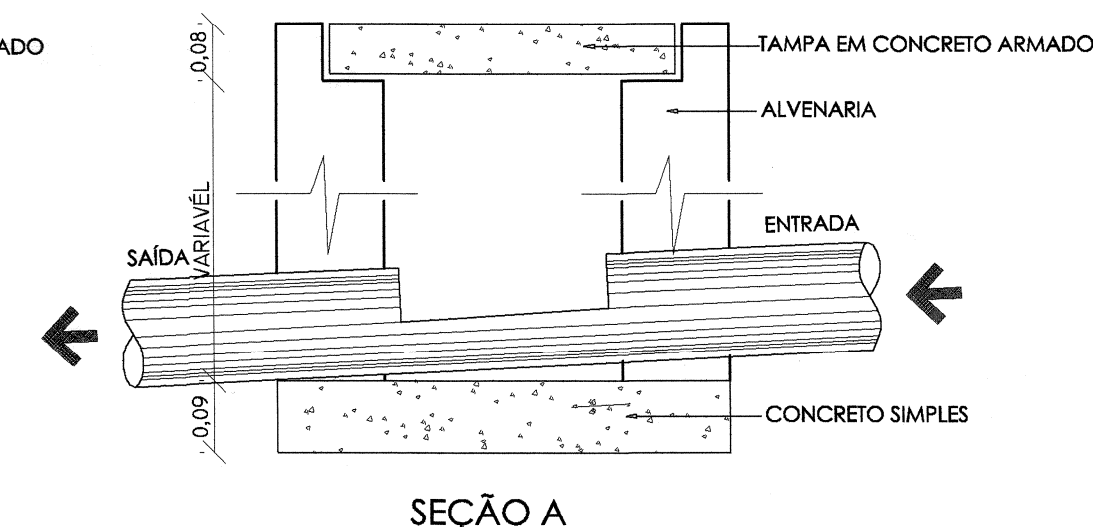
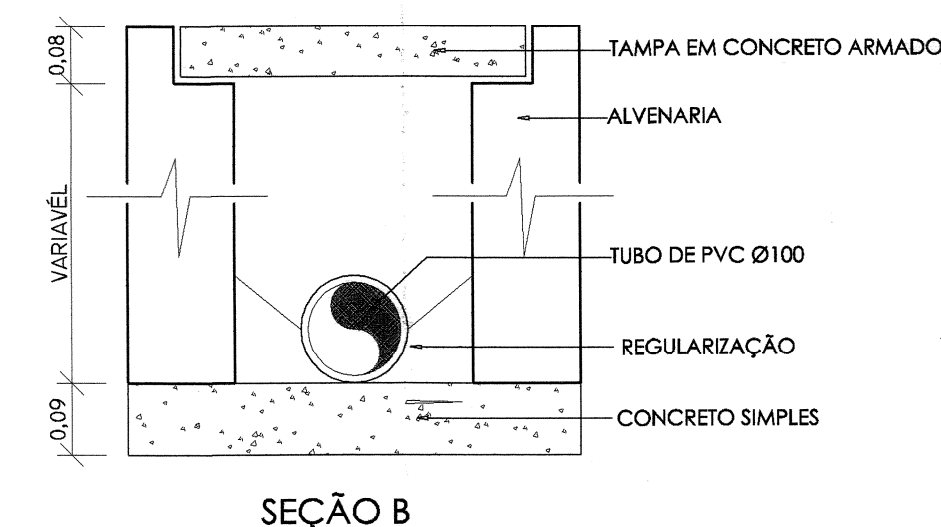
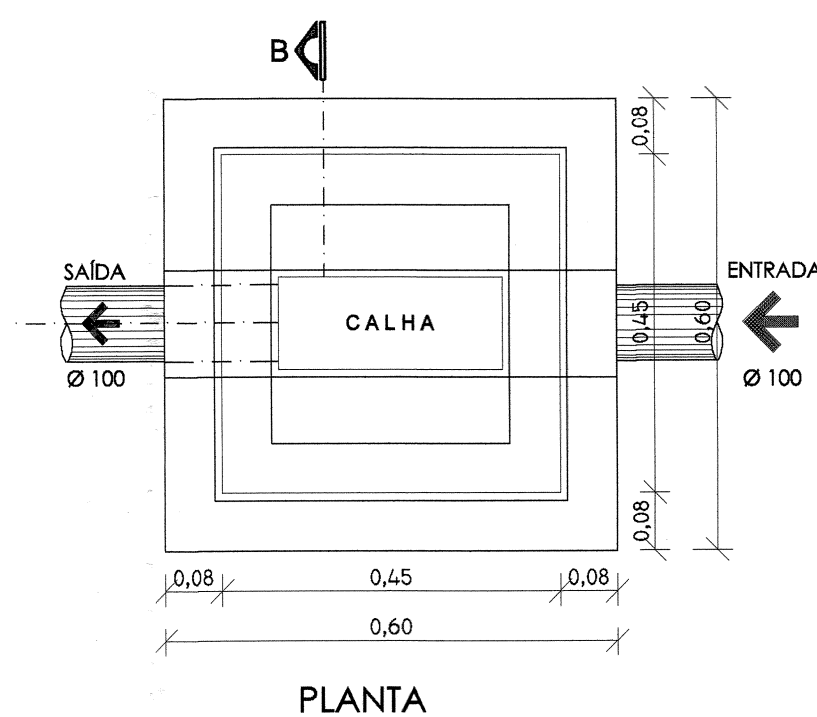

**CAIXA DE GORDURA**  
ESCALA: 1/10

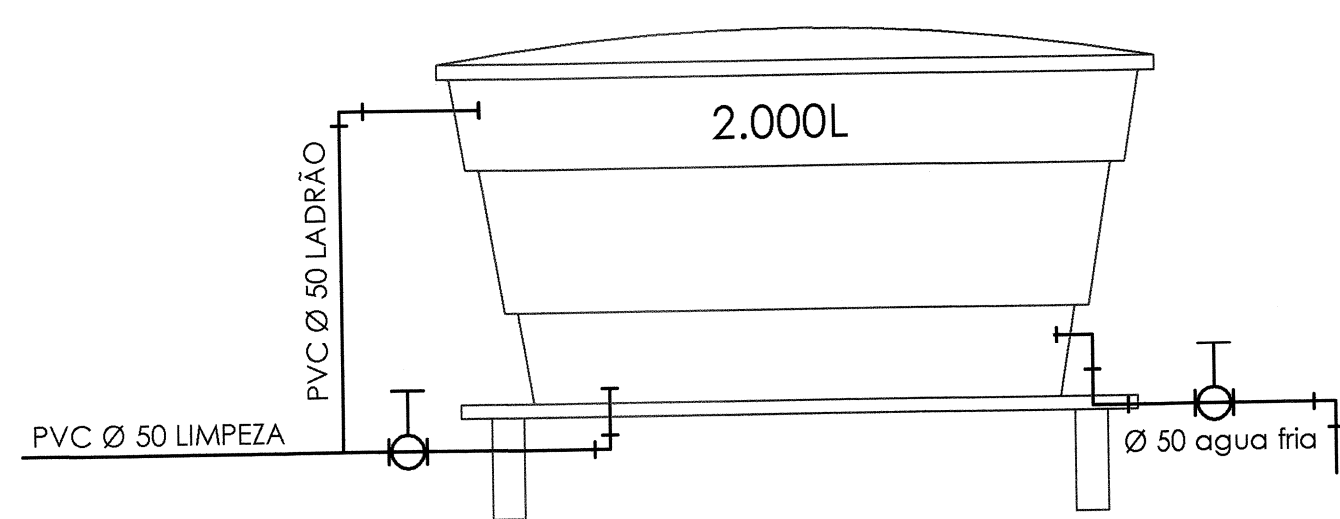
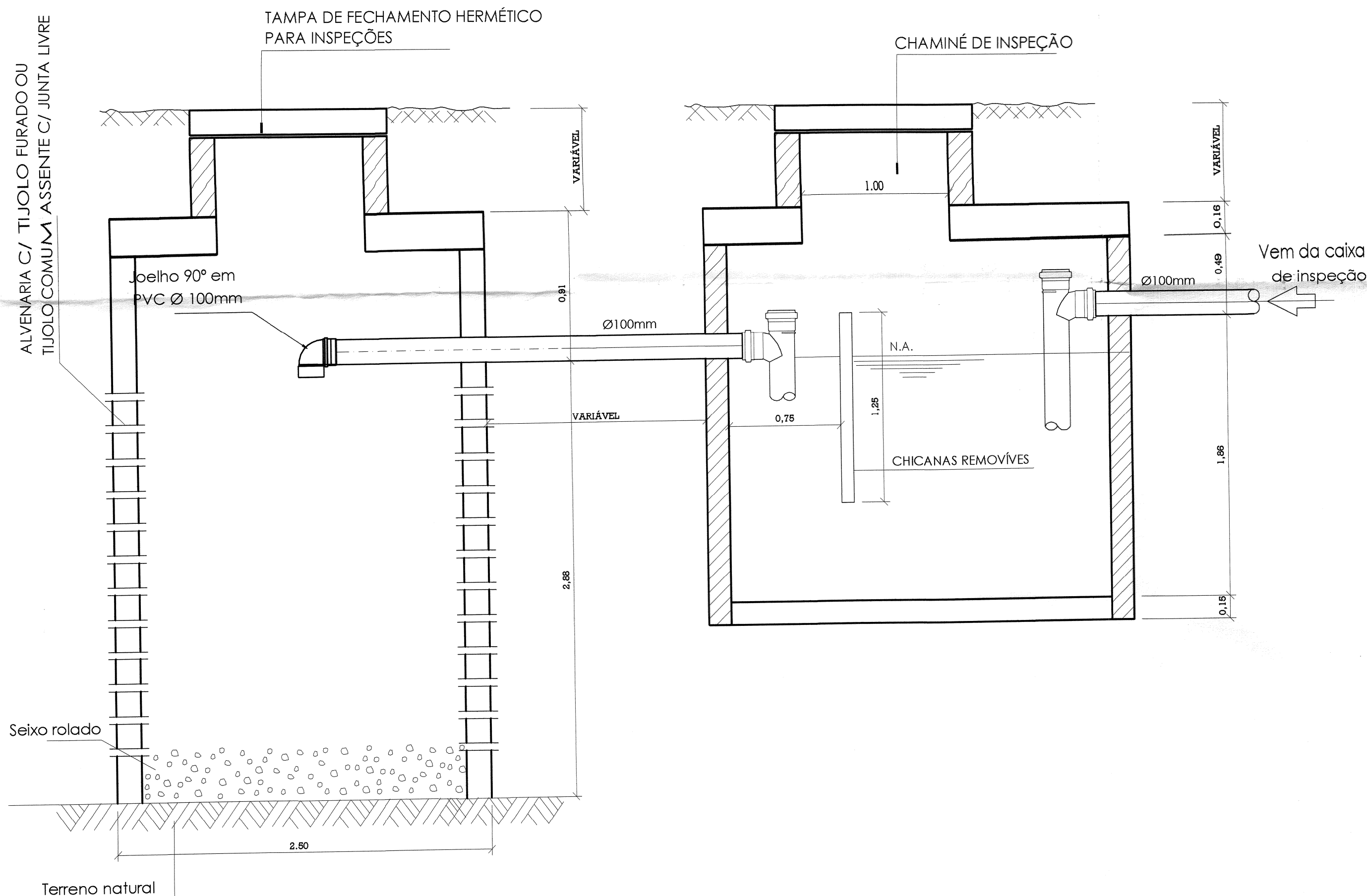
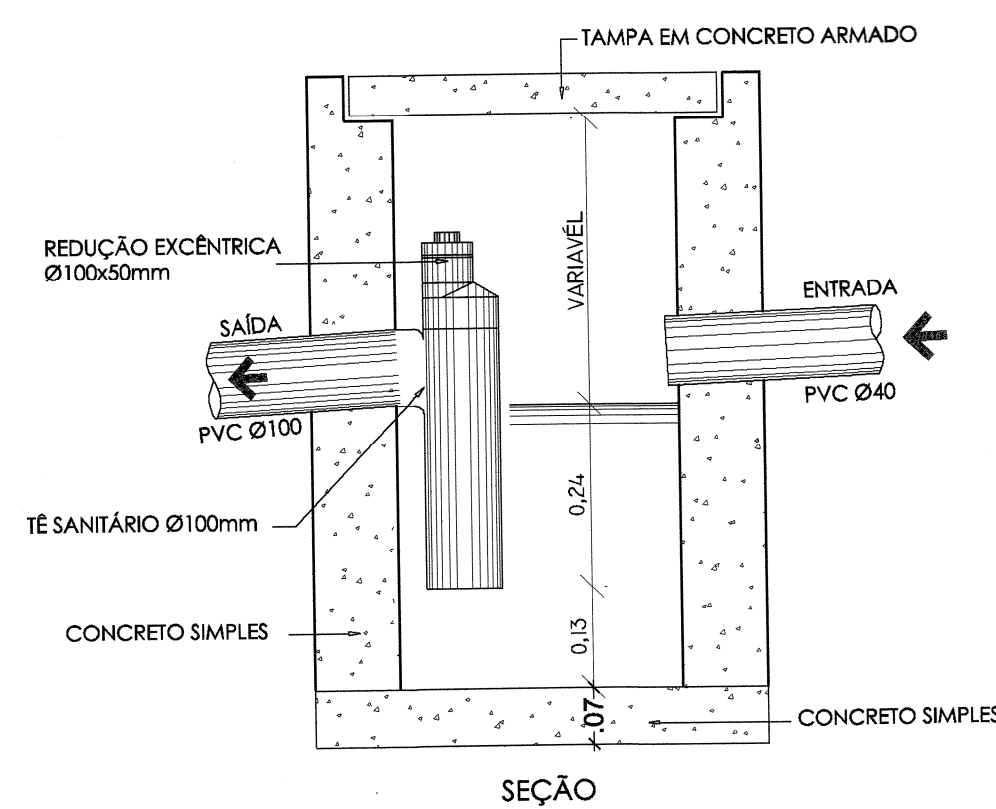
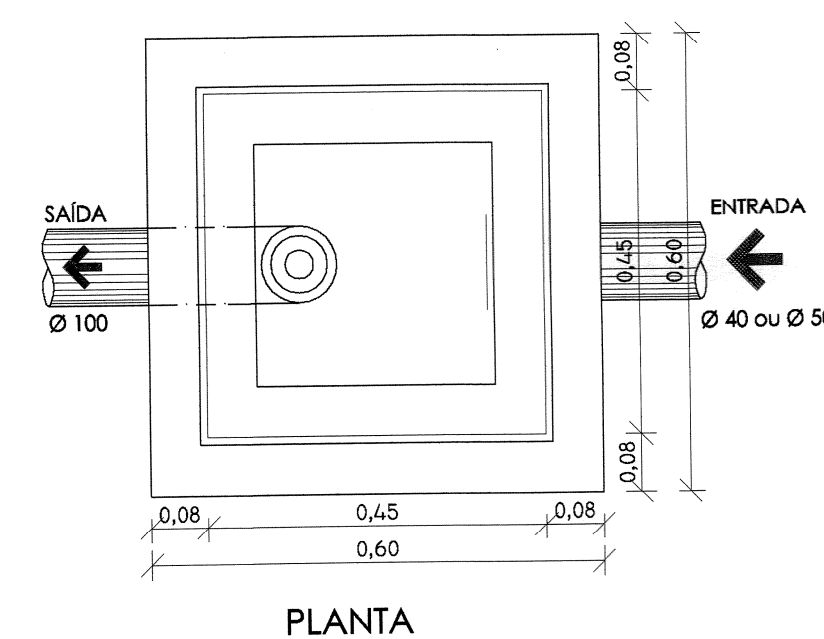

PROCESSO N°  
1021363 97  
FLS.: 13

<b>CONSTRUTORA ANDRADE RIBEIRO LTDA</b>		<b>PROJETO HIDROSSANITÁRIO</b>	
<b>CENTRO DE REFERÊNCIA DE ASSISTÊNCIA SOCIAL- CRAS</b> (PREFEITURA MUNICIPAL DE SENADOR JOSÉ PORFÍRIO)			
AUTOR DO PROJETO:	<i>Paulo Mognó Oliveira Moura Silva</i>	PROPRIETÁRIO:	<i>Paulo Mognó Oliveira Moura Silva</i>
PAULO MOGNÓ OLIVEIRA MOURA SILVA CAU - A72399-1		PREFEITURA MUNICIPAL DE SENADOR JOSÉ PORFÍRIO C.N.P.J. 06.423190/0001-40	
CONTEÚDO:	FOSSA SÉPTICA SUMIDOURO	DET. DA CAIXA DE GORDURA DET. DA CAIXA DE INSPEÇÃO	ESCALA:
ENDEREÇO:	TRAV. SÃO FRANCISCO, ESG. COM RUA JOÃO INÁCIO DE SOUSA s/nº, SENADOR JOSÉ PORFÍRIO - PA.	CEP: 68.360-000	DATA: ABRIL / 2015
OBSERVAÇÕES:		ÁREA TOTAL CONSTRUIDA:	170,41 m²
		ÁREA DO TERRENO:	450,00 m²
		FRANCA:	<b>02</b>
			<b>02</b>

